

AXO

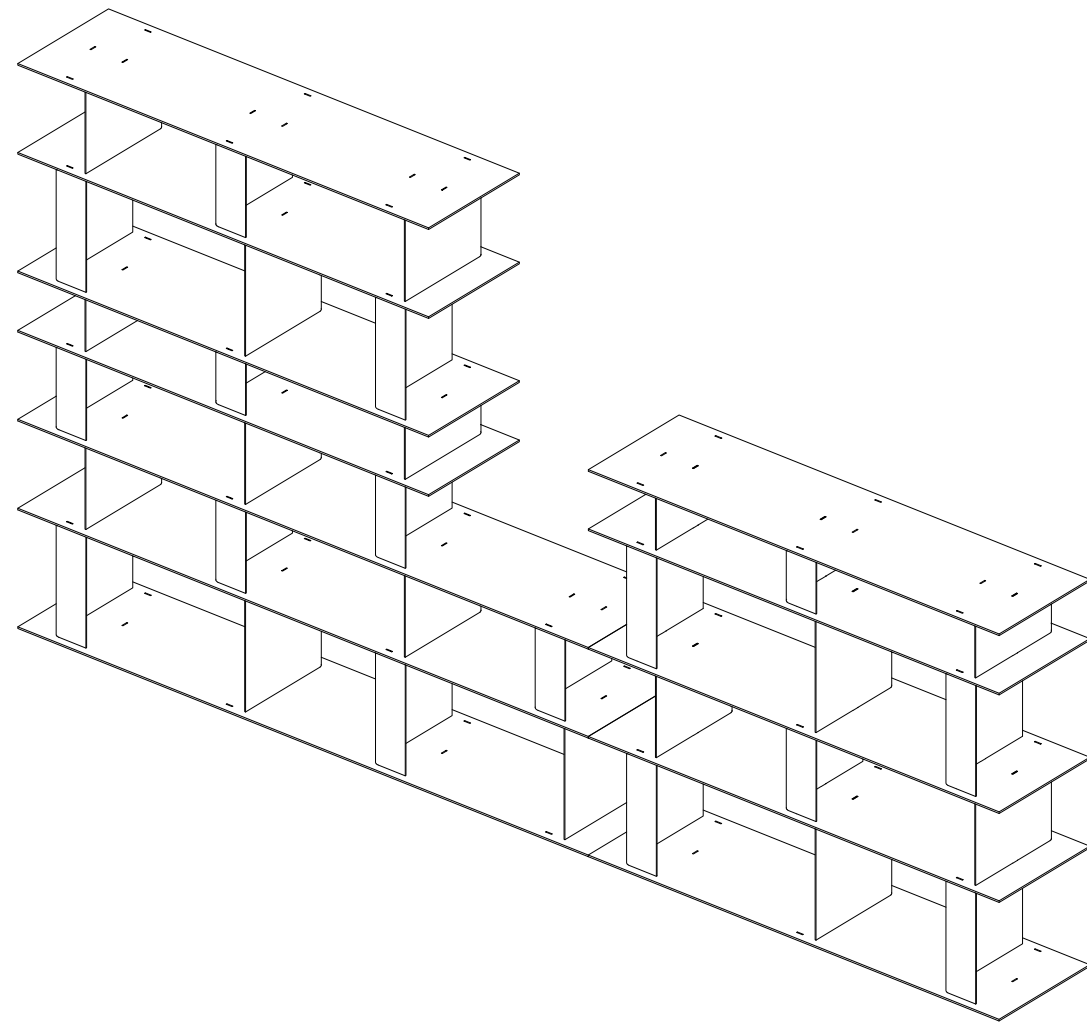

PLAN

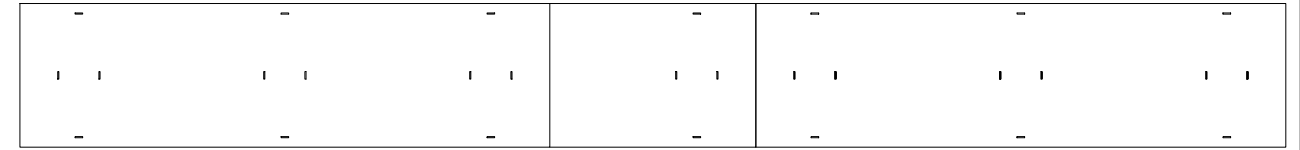

FRONT

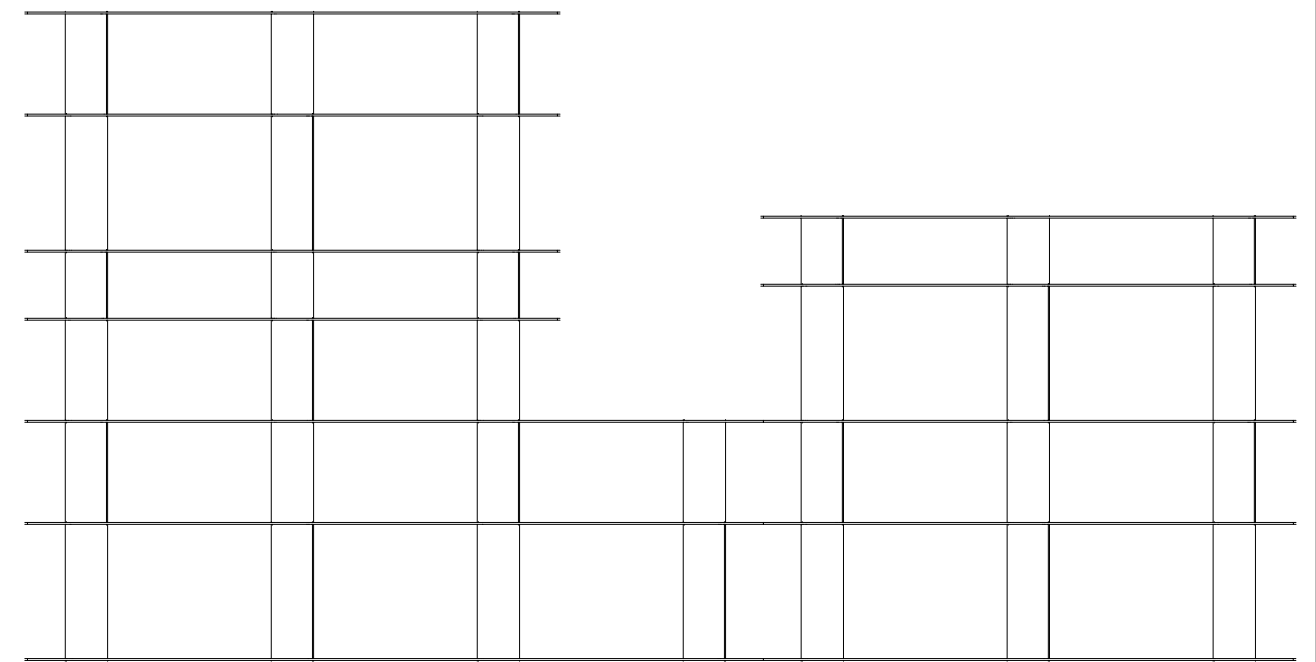

STACK by studio MOTO

[www.studioMOTO.be](http://www.studioMOTO.be) [info@studioMOTO.be](mailto:info@studioMOTO.be)

STACK 01

AXO

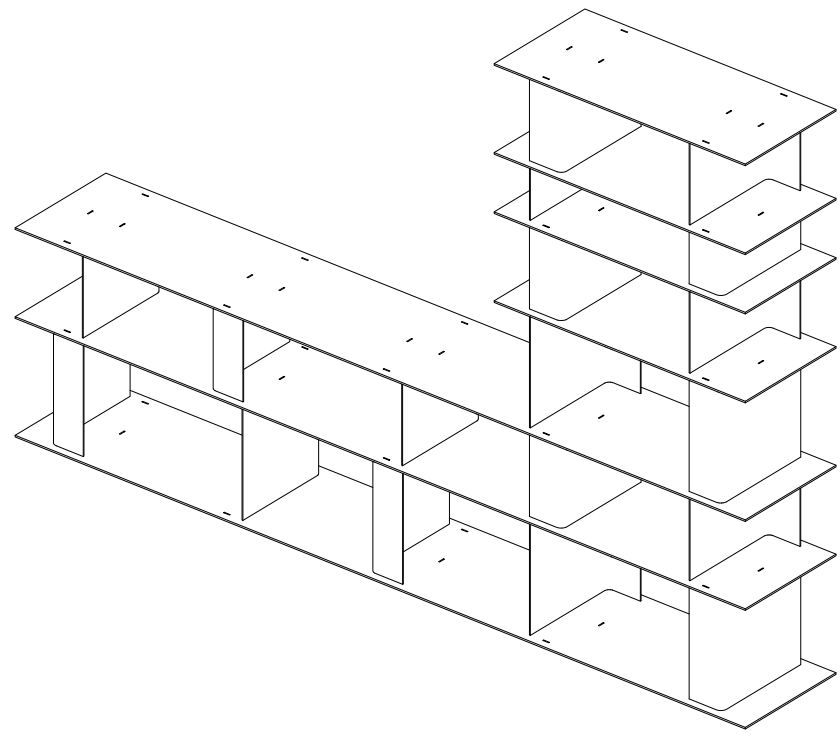

PLAN

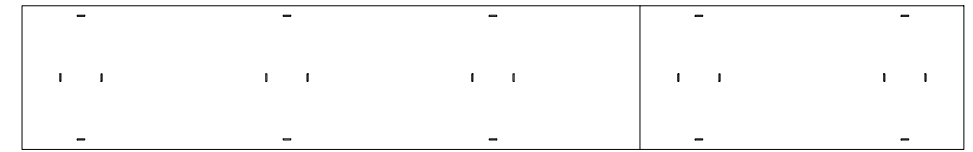

FRONT

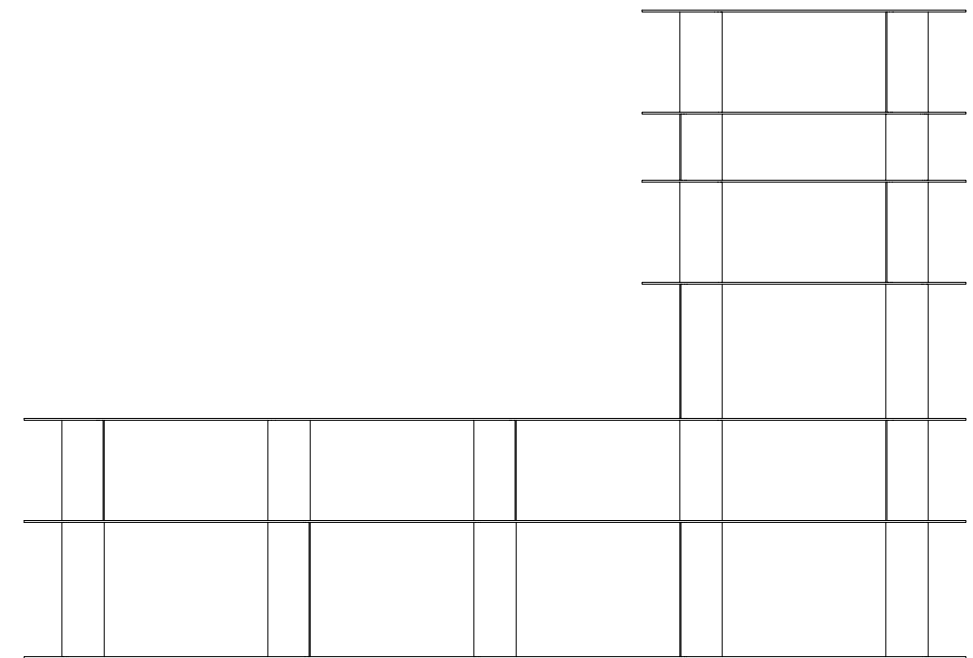

STACK by studio MOTO

[www.studioMOTO.be](http://www.studioMOTO.be) [info@studioMOTO.be](mailto:info@studioMOTO.be)

STACK 02

AXO

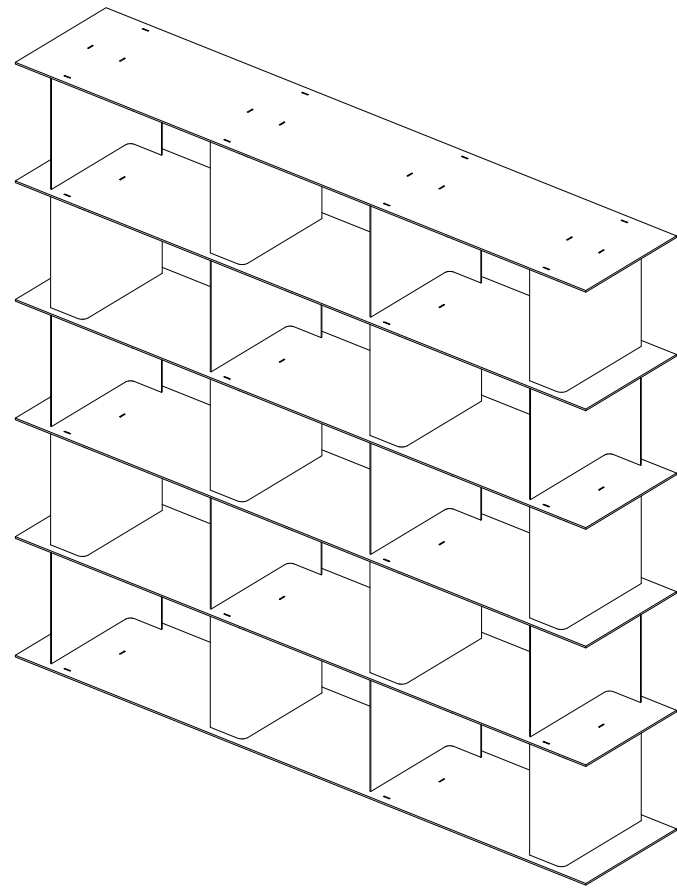

PLAN



FRONT

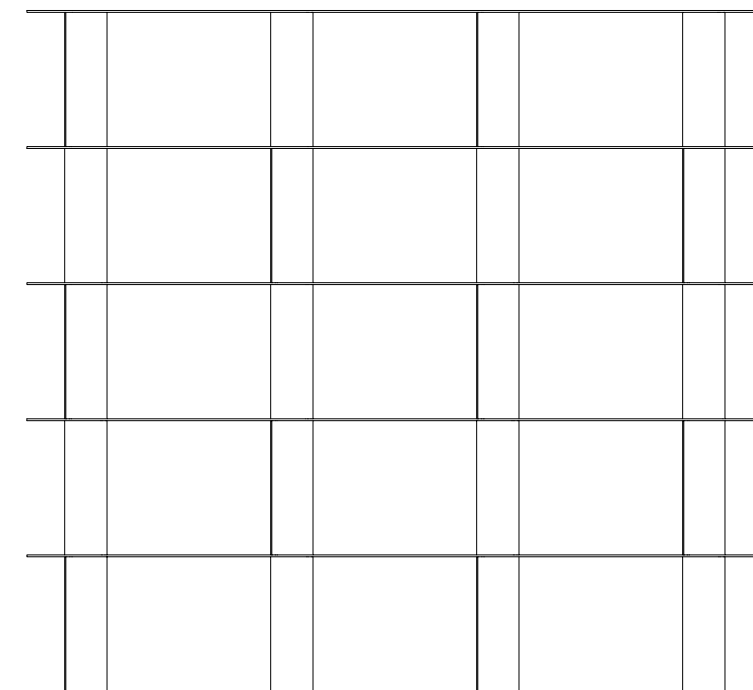

STACK by studio MOTO

[www.studioMOTO.be](http://www.studioMOTO.be) [info@studioMOTO.be](mailto:info@studioMOTO.be)

STACK 03

AXO

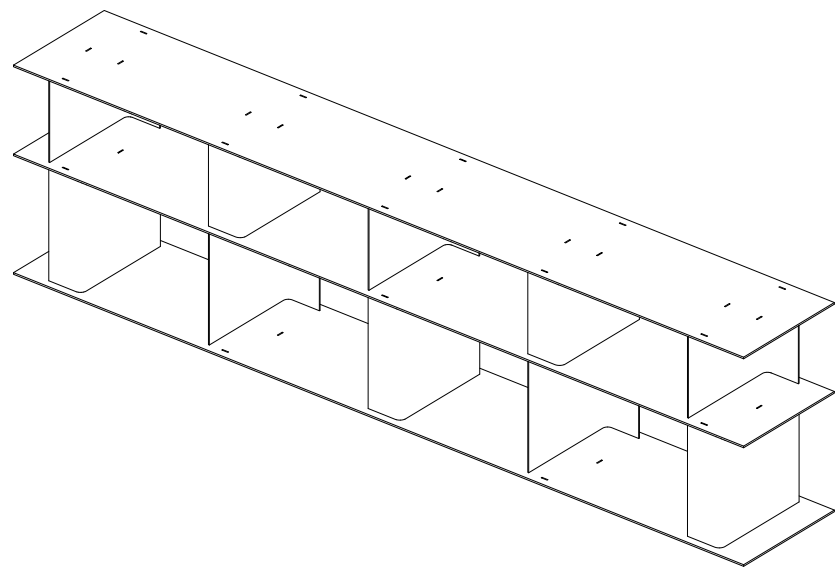

PLAN

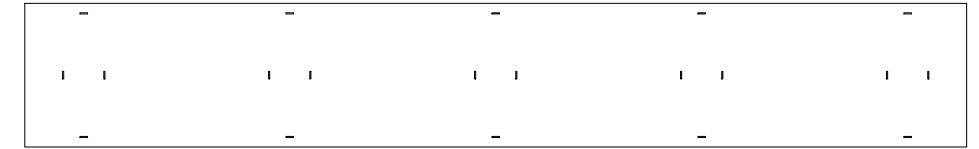

FRONT

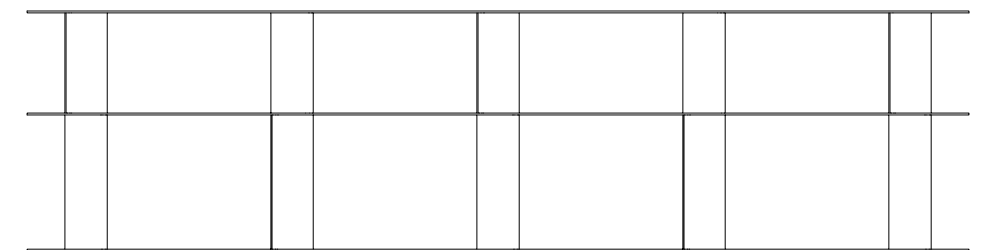

STACK by studio MOTO

[www.studioMOTO.be](http://www.studioMOTO.be) [info@studioMOTO.be](mailto:info@studioMOTO.be)

STACK 04

AXO

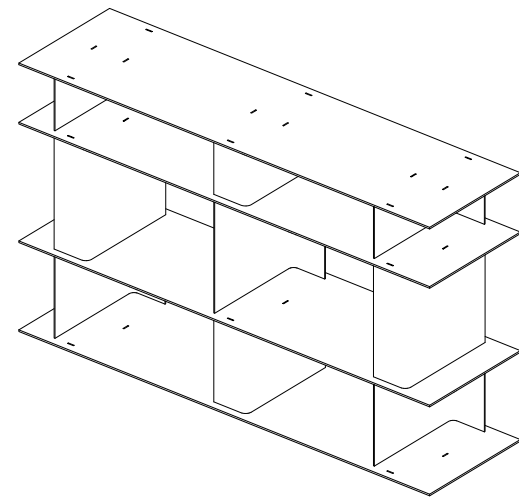

PLAN

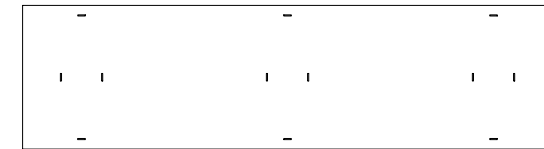

FRONT

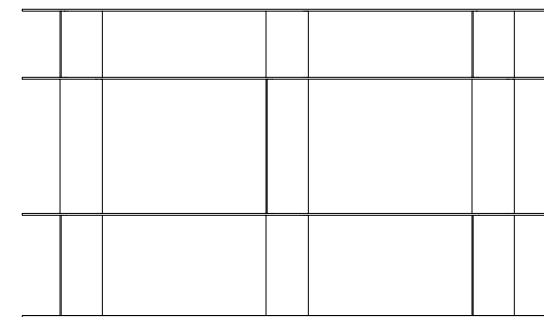

STACK by studio MOTO

[www.studioMOTO.be](http://www.studioMOTO.be) [info@studioMOTO.be](mailto:info@studioMOTO.be)

STACK 05

AXO

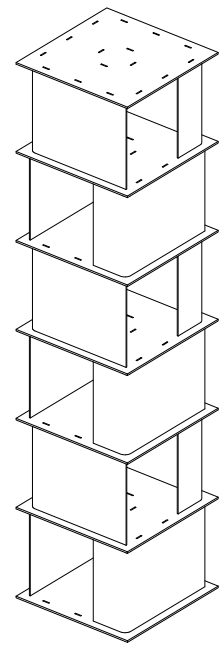

PLAN

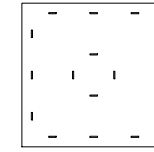

FRONT

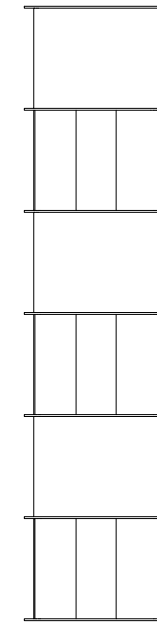

STACK by studio MOTO

[www.studioMOTO.be](http://www.studioMOTO.be) [info@studioMOTO.be](mailto:info@studioMOTO.be)

STACK 06

AXO

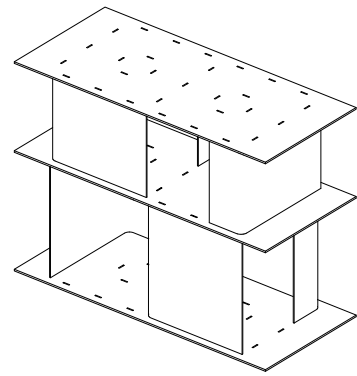

PLAN

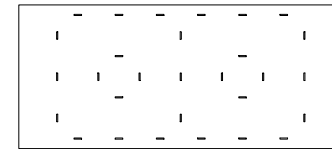

FRONT

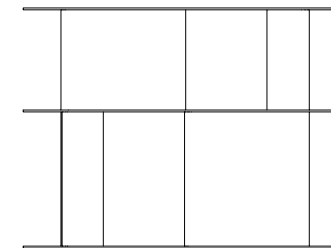

STACK by studio MOTO

[www.studioMOTO.be](http://www.studioMOTO.be) [info@studioMOTO.be](mailto:info@studioMOTO.be)

STACK 07

AXO

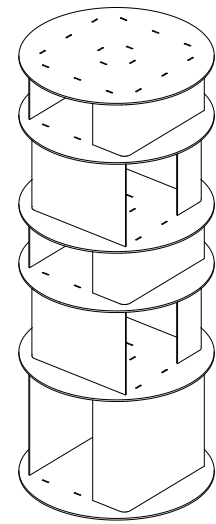

PLAN

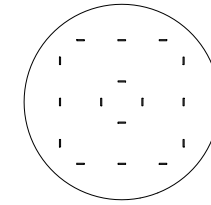

FRONT

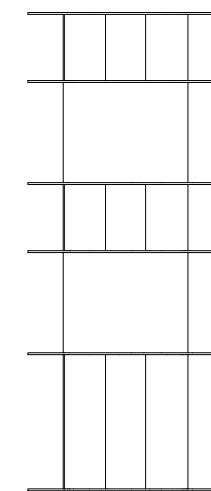

STACK by studio MOTO

[www.studioMOTO.be](http://www.studioMOTO.be) [info@studioMOTO.be](mailto:info@studioMOTO.be)

STACK 08



AXO

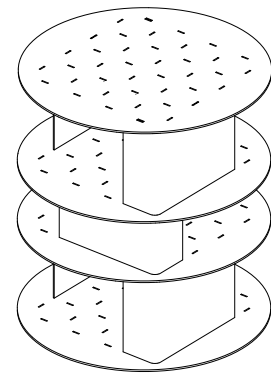

PLAN

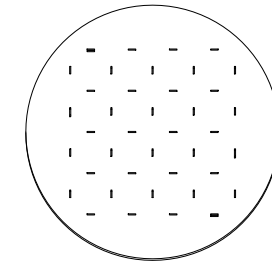

FRONT

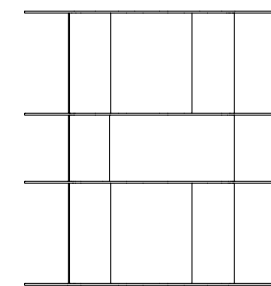

STACK by studio MOTO

[www.studioMOTO.be](http://www.studioMOTO.be) [info@studioMOTO.be](mailto:info@studioMOTO.be)

STACK 09

AXO

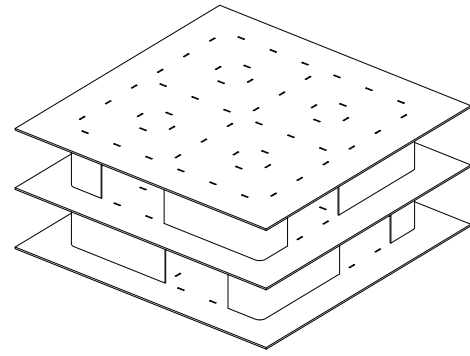

PLAN

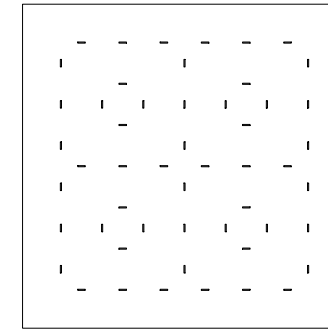

FRONT

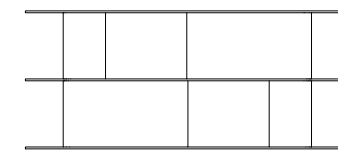

STACK by studio MOTO  
www.studioMOTO.be info@studioMOTO.be

STACK 10

AXO

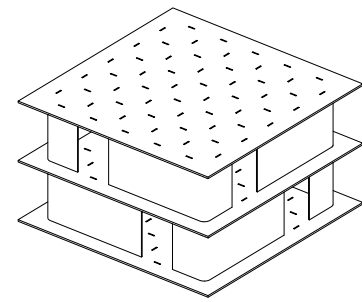

PLAN

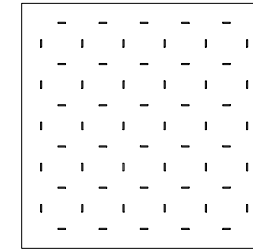

FRONT

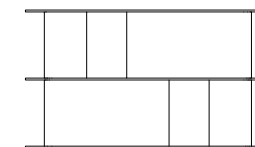

STACK by studio MOTO

[www.studioMOTO.be](http://www.studioMOTO.be) [info@studioMOTO.be](mailto:info@studioMOTO.be)

STACK II

AXO

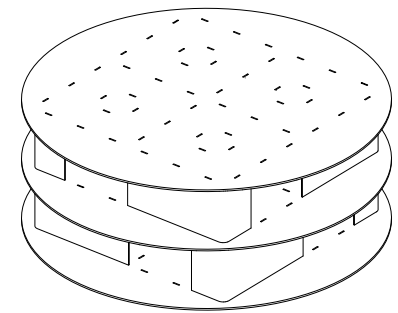

PLAN

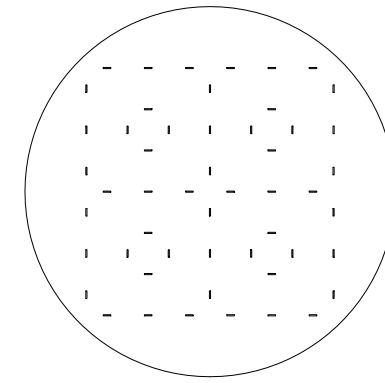

FRONT

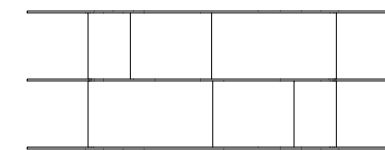

STACK by studio MOTO

[www.studioMOTO.be](http://www.studioMOTO.be) [info@studioMOTO.be](mailto:info@studioMOTO.be)

STACK 12

AXO

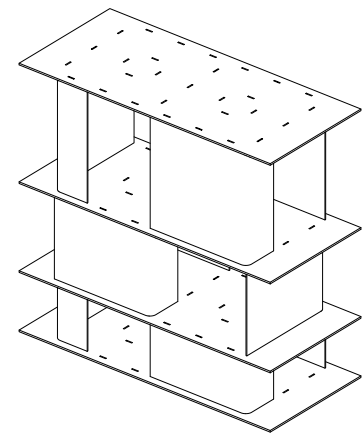

PLAN

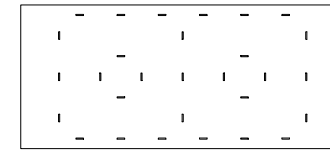

FRONT

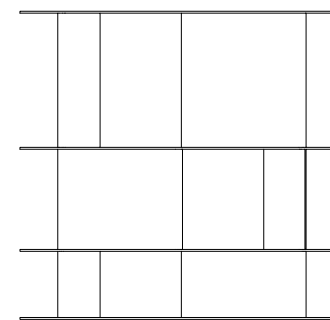

STACK by studio MOTO

[www.studioMOTO.be](http://www.studioMOTO.be) [info@studioMOTO.be](mailto:info@studioMOTO.be)

STACK 13

AXO

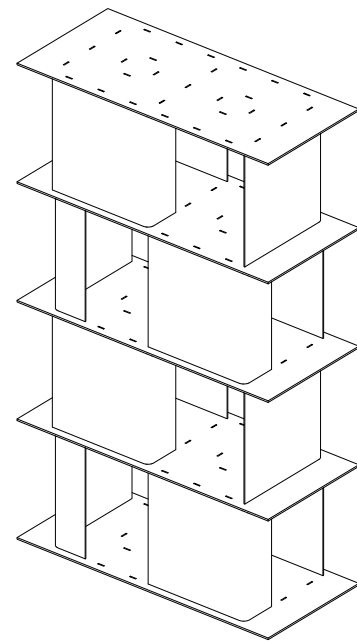

PLAN

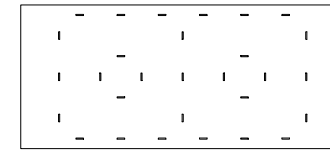

FRONT

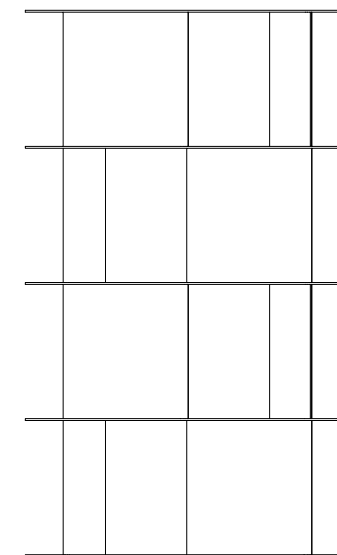

STACK by studio MOTO  
www.studioMOTO.be info@studioMOTO.be

STACK 14

AXO

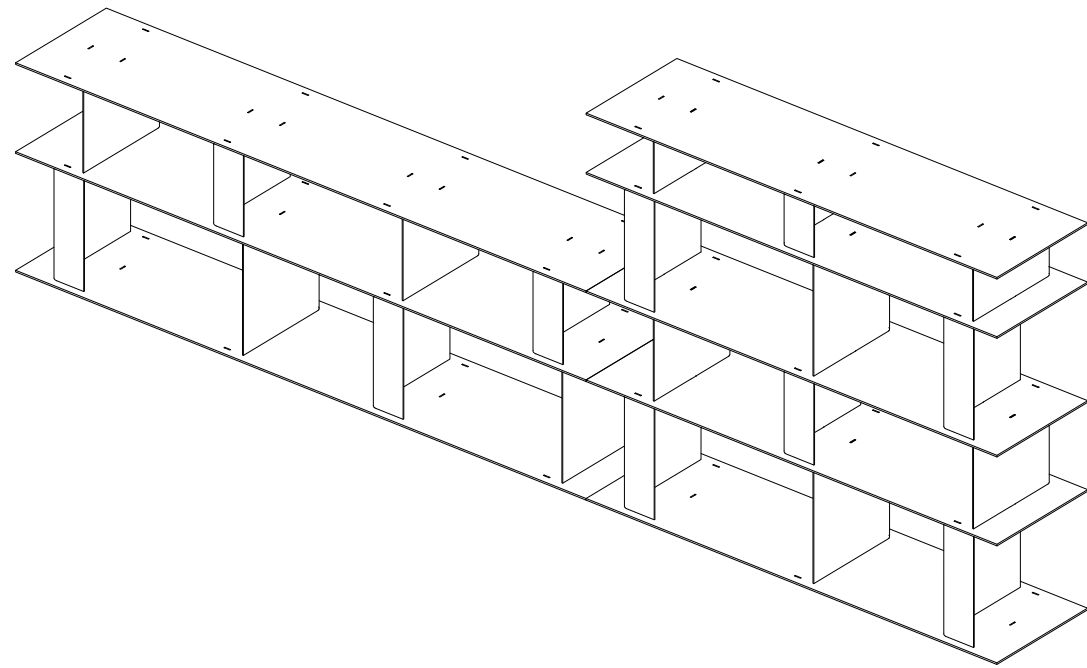

PLAN

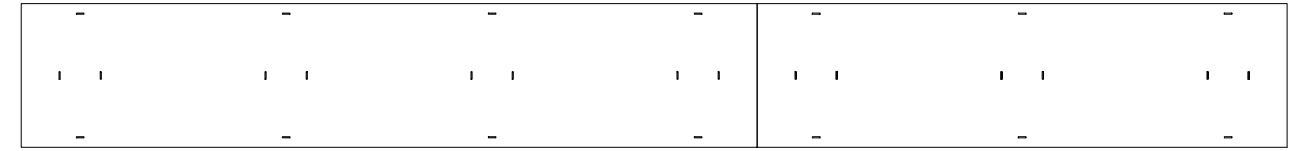

FRONT

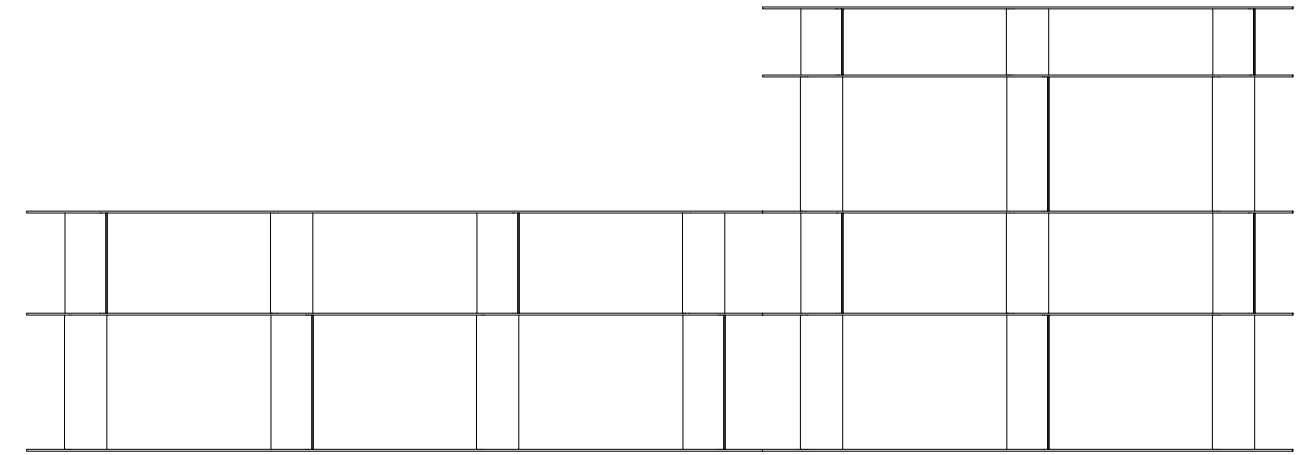

STACK by studio MOTO

[www.studioMOTO.be](http://www.studioMOTO.be) [info@studioMOTO.be](mailto:info@studioMOTO.be)

STACK 15

AXO

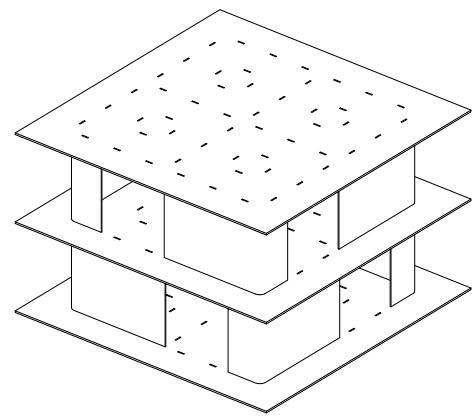

PLAN

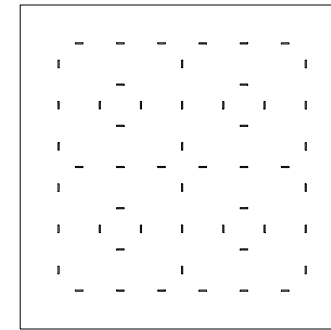

FRONT

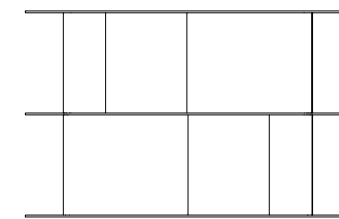

STACK by studio MOTO

[www.studioMOTO.be](http://www.studioMOTO.be) [info@studioMOTO.be](mailto:info@studioMOTO.be)

STACK 16



AXO

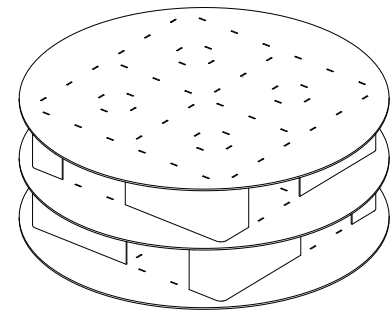

PLAN

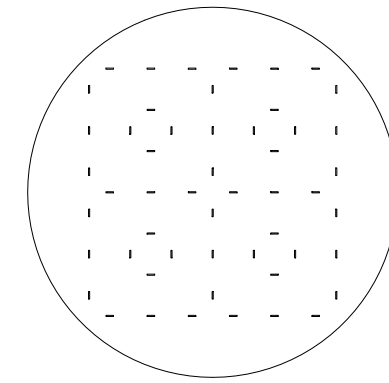

FRONT

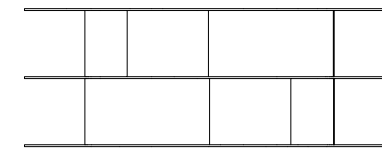

STACK by studio MOTO

[www.studioMOTO.be](http://www.studioMOTO.be) [info@studioMOTO.be](mailto:info@studioMOTO.be)

STACK 17

AXO

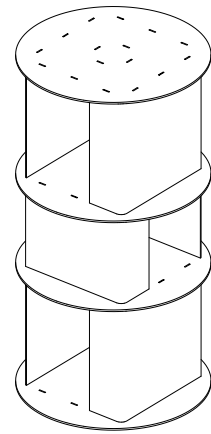

PLAN

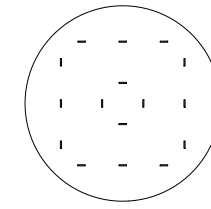

FRONT

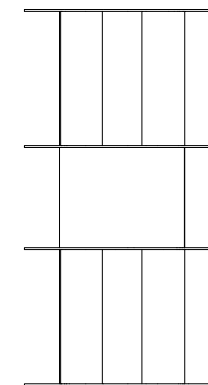

STACK by studio MOTO  
www.studioMOTO.be info@studioMOTO.be

STACK 18

AXO

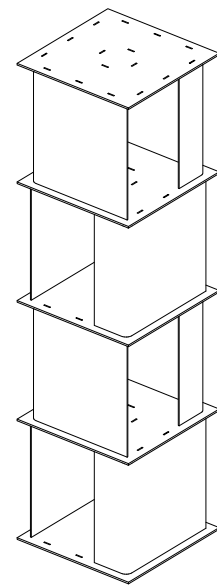

PLAN

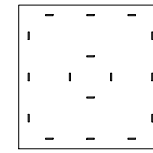

FRONT

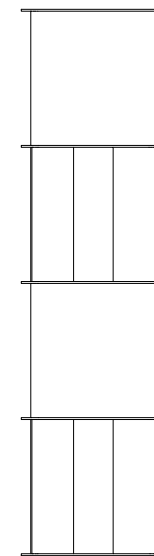

STACK by studio MOTO

[www.studioMOTO.be](http://www.studioMOTO.be) [info@studioMOTO.be](mailto:info@studioMOTO.be)

STACK 19

AXO

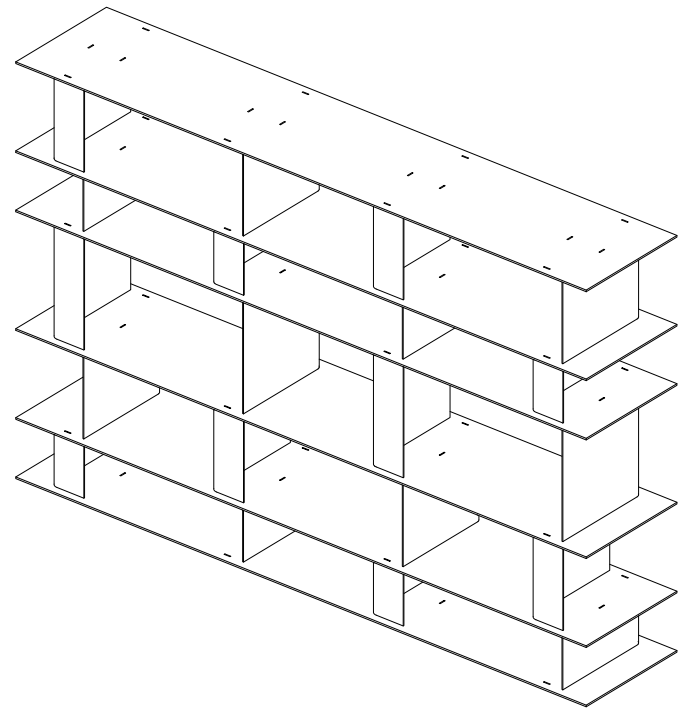

PLAN



FRONT

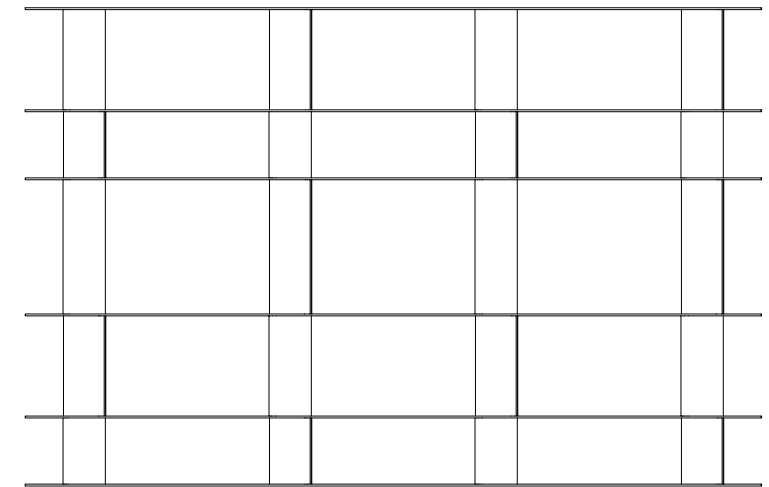

STACK by studio MOTO

[www.studioMOTO.be](http://www.studioMOTO.be) [info@studioMOTO.be](mailto:info@studioMOTO.be)

STACK 20

AXO

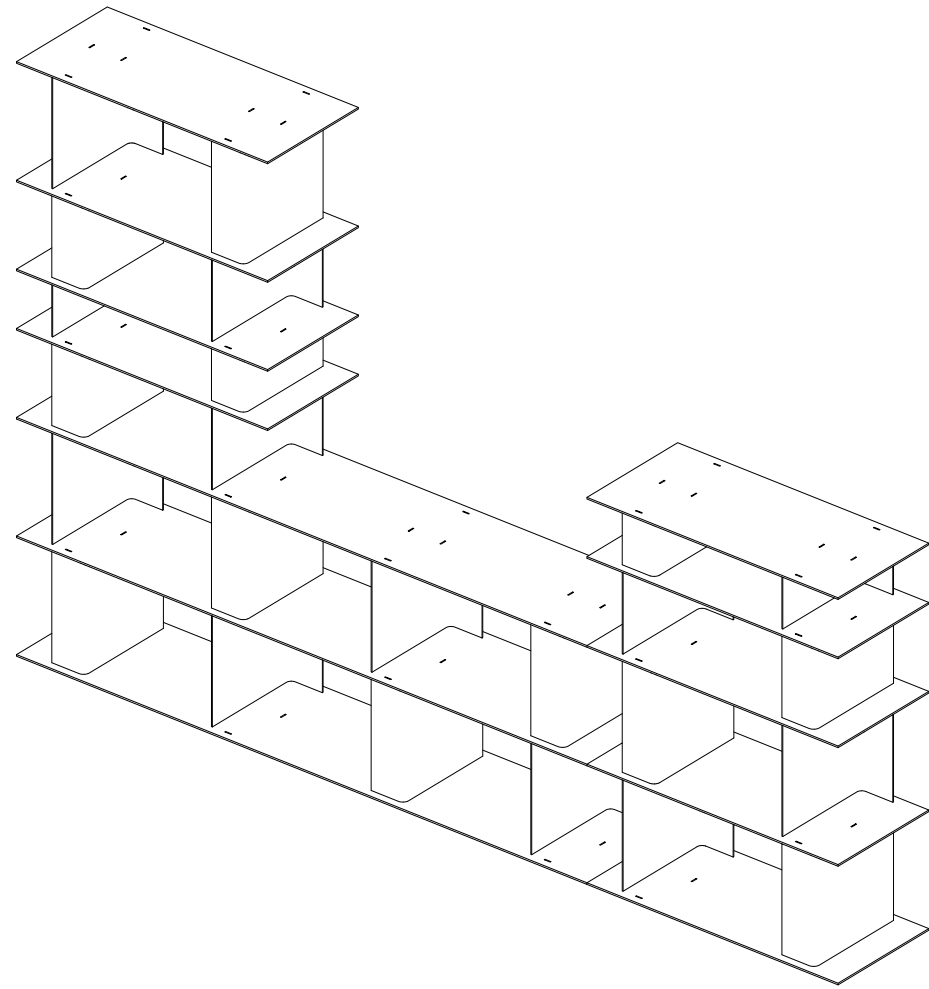

PLAN



FRONT

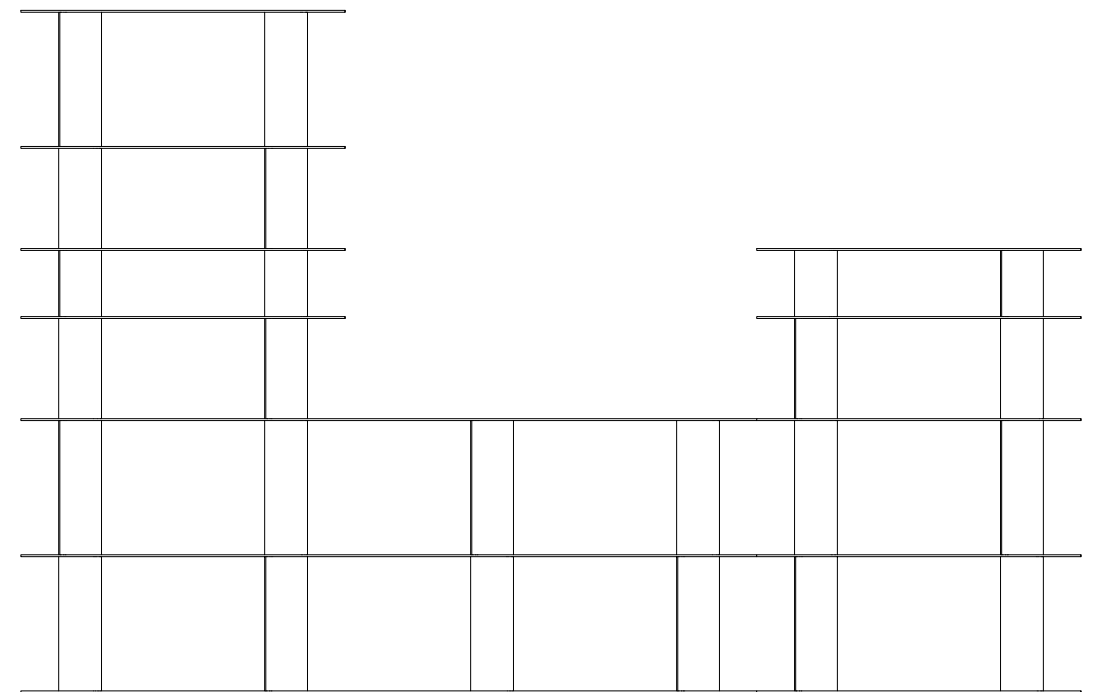

STACK by studio MOTO

[www.studioMOTO.be](http://www.studioMOTO.be) [info@studioMOTO.be](mailto:info@studioMOTO.be)

STACK 21

AXO

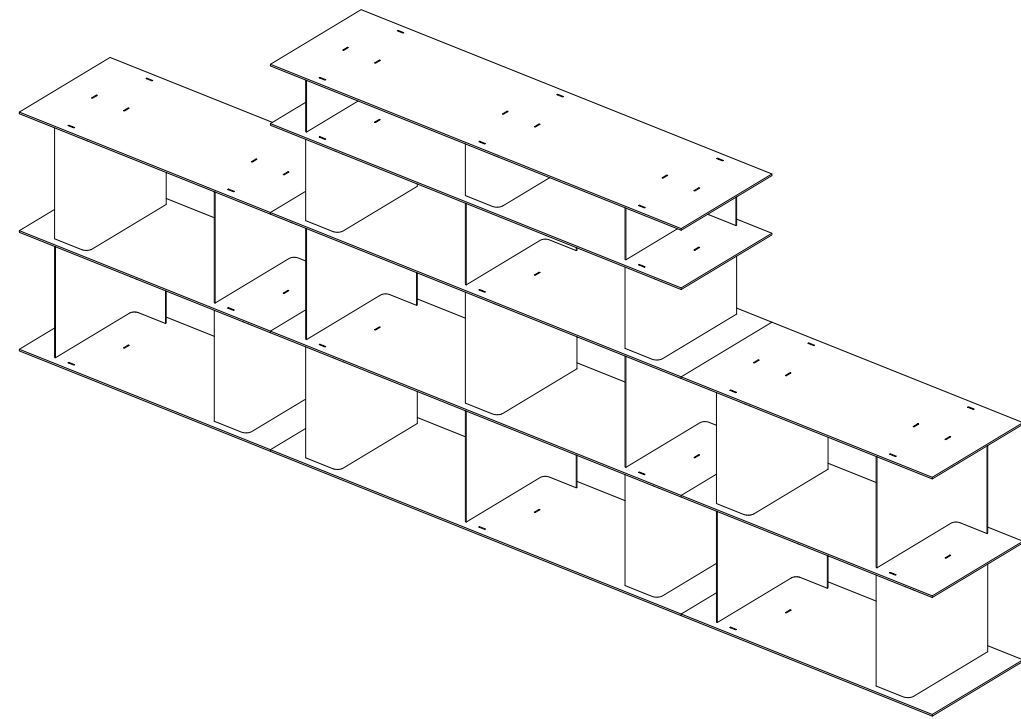

PLAN

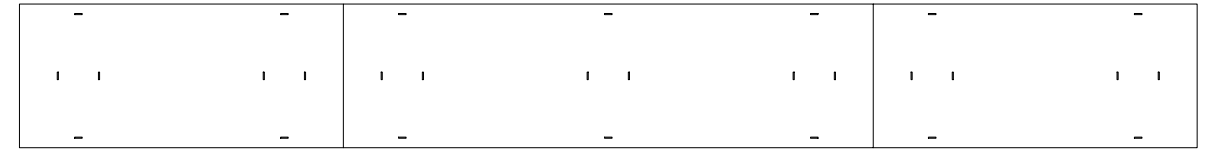

FRONT

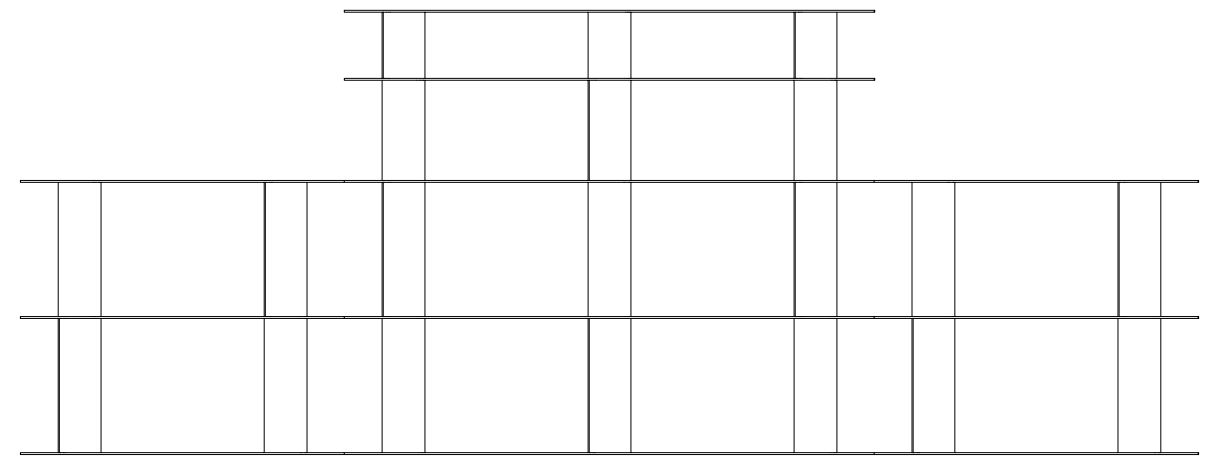

STACK by studio MOTO

[www.studioMOTO.be](http://www.studioMOTO.be) [info@studioMOTO.be](mailto:info@studioMOTO.be)

STACK 22

AXO

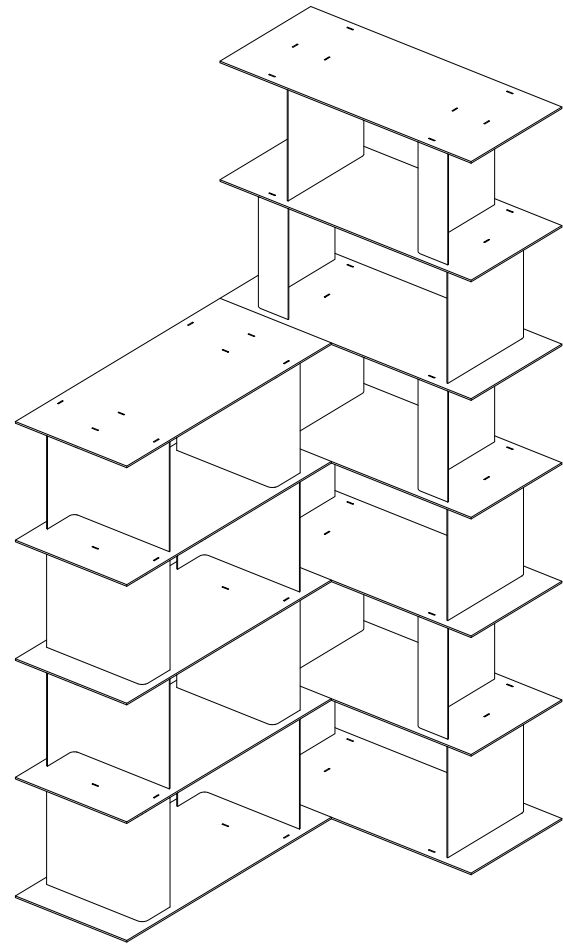

PLAN

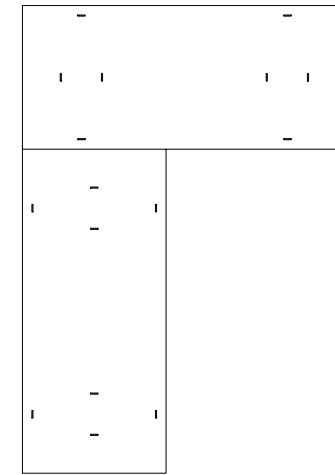

FRONT

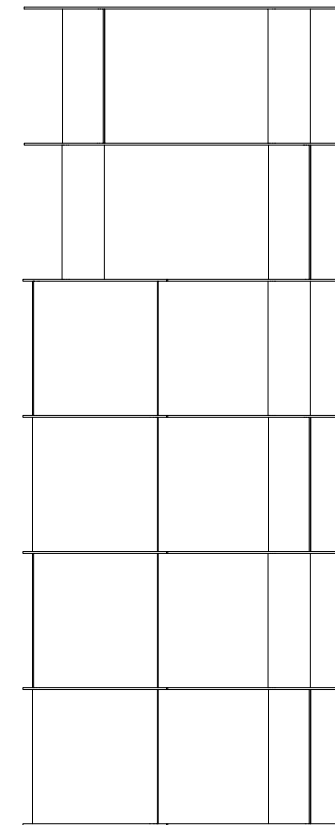

STACK by studio MOTO

[www.studioMOTO.be](http://www.studioMOTO.be) [info@studioMOTO.be](mailto:info@studioMOTO.be)

STACK 23

AXO

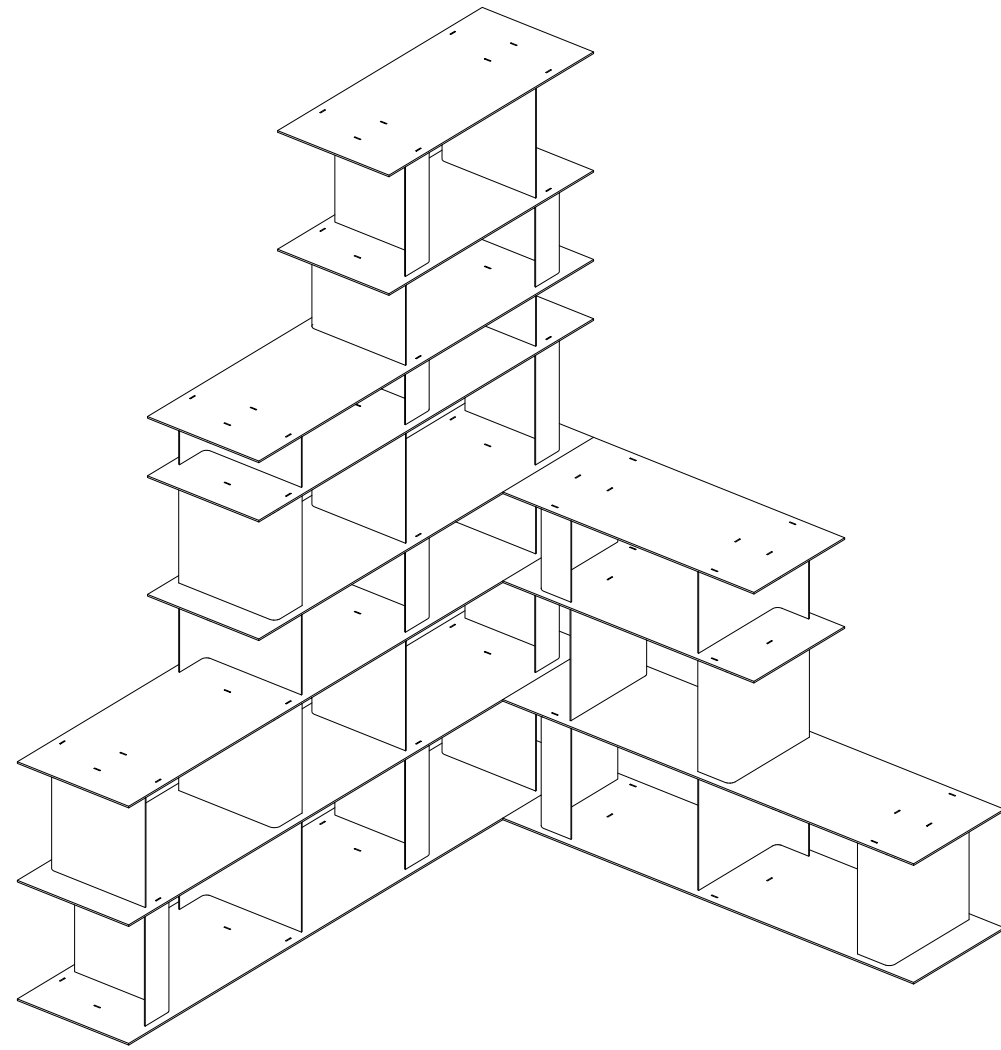

PLAN

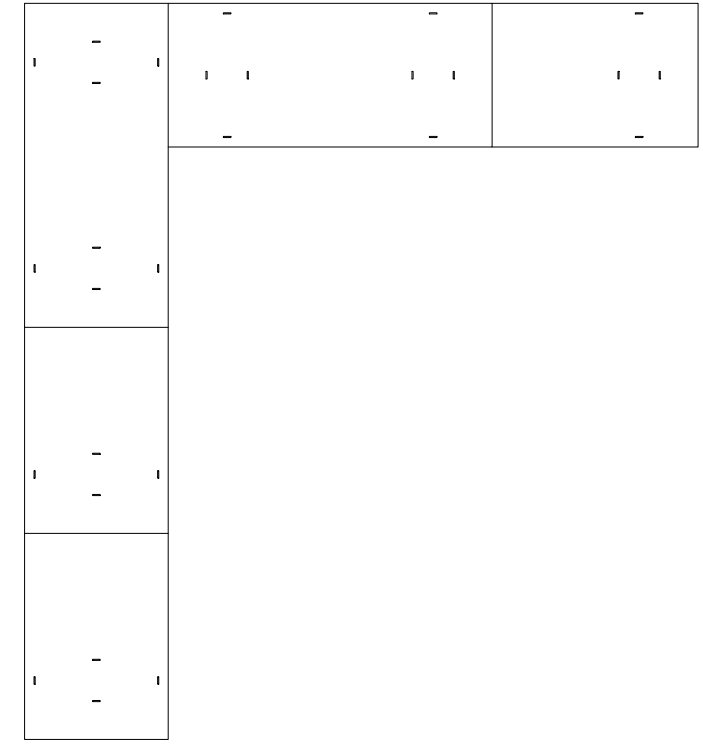

FRONT

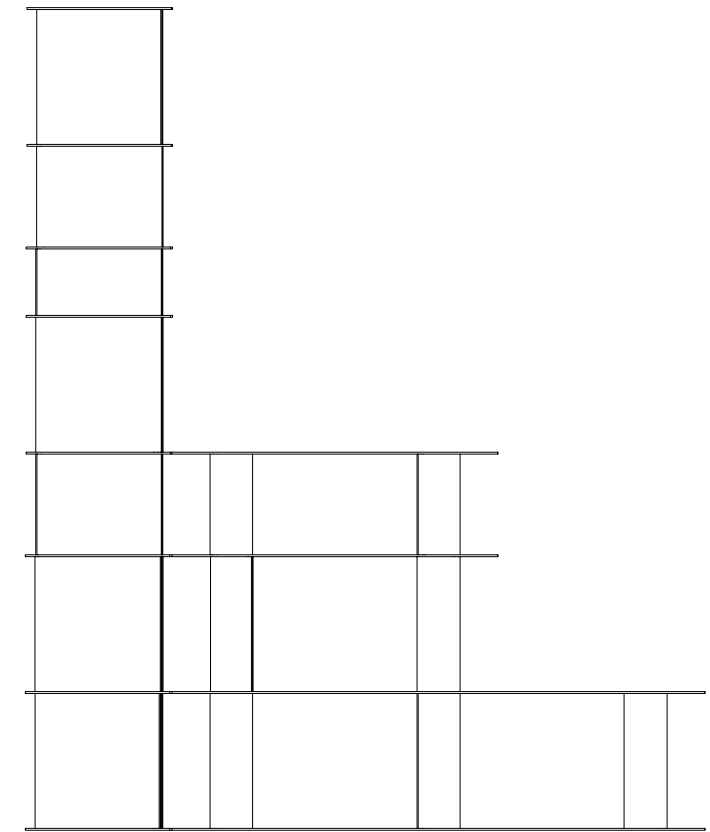

STACK by studio MOTO

[www.studioMOTO.be](http://www.studioMOTO.be) [info@studioMOTO.be](mailto:info@studioMOTO.be)

STACK 24



AXO

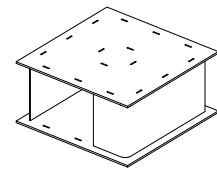

PLAN

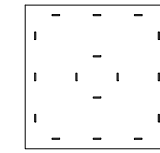

FRONT

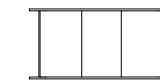

STACK by studio MOTO

[www.studioMOTO.be](http://www.studioMOTO.be) [info@studioMOTO.be](mailto:info@studioMOTO.be)

STACK 25

AXO

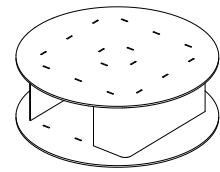

PLAN

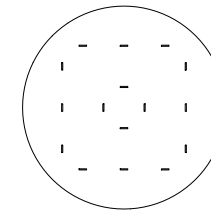

FRONT

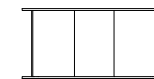

STACK by studio MOTO

[www.studioMOTO.be](http://www.studioMOTO.be) [info@studioMOTO.be](mailto:info@studioMOTO.be)

STACK 26

AXO

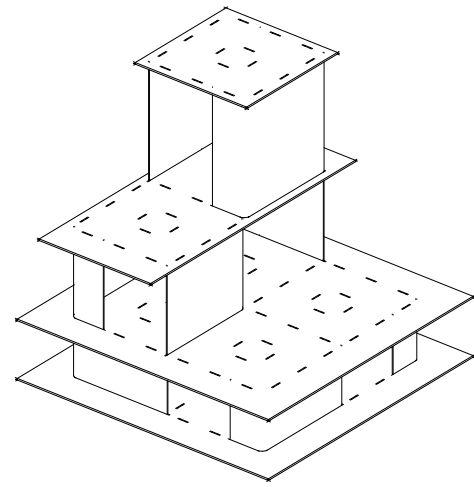

PLAN

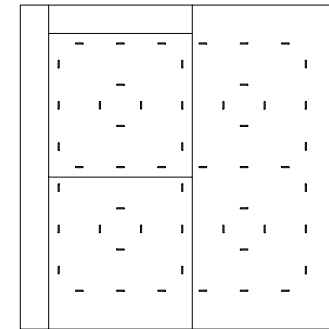

FRONT

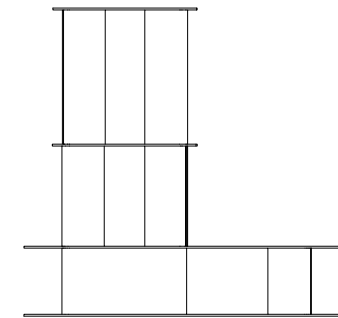

STACK by studio MOTO

[www.studioMOTO.be](http://www.studioMOTO.be) [info@studioMOTO.be](mailto:info@studioMOTO.be)

STACK 27

AXO

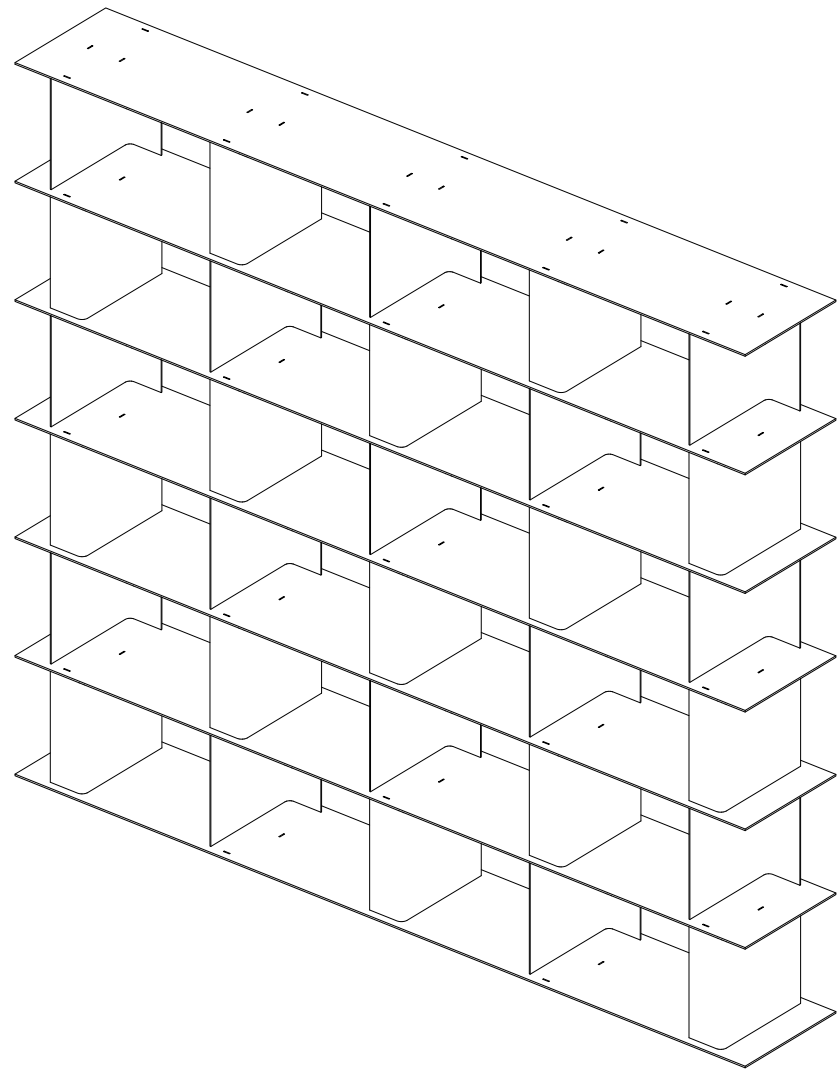

PLAN

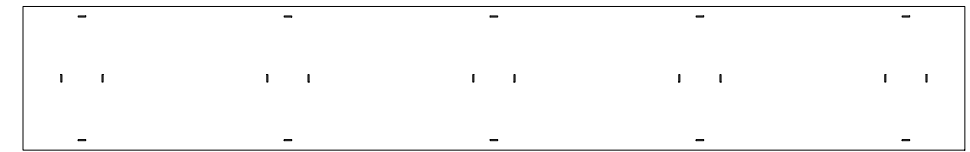

FRONT

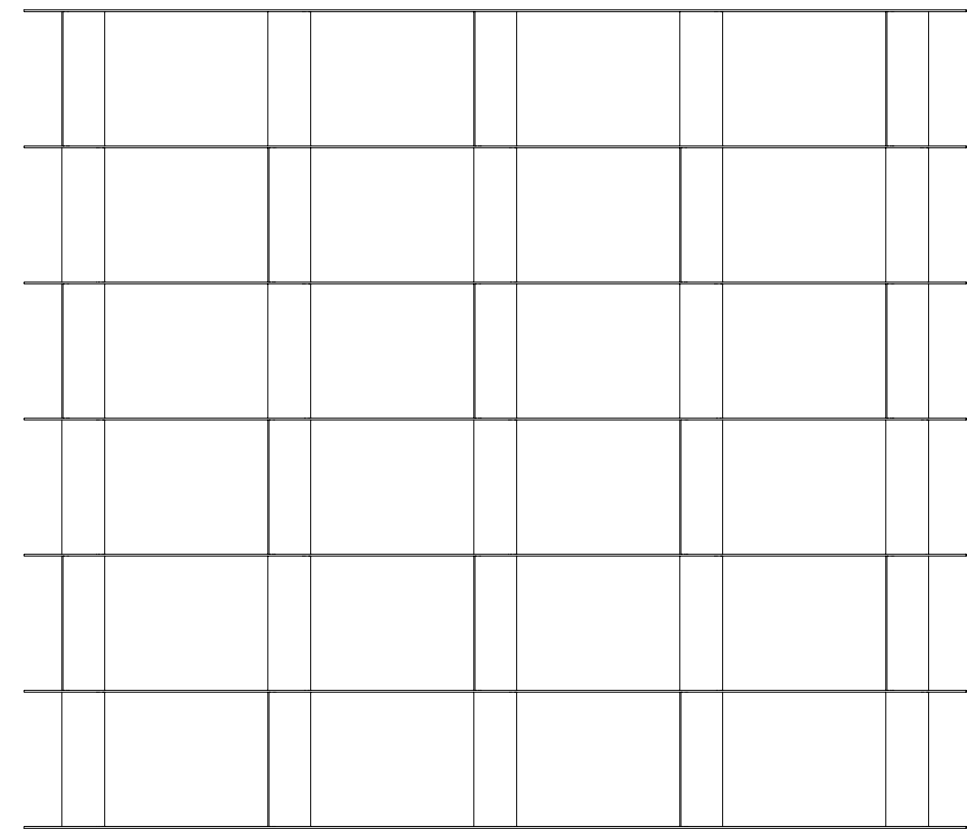

STACK by studio MOTO

[www.studioMOTO.be](http://www.studioMOTO.be) [info@studioMOTO.be](mailto:info@studioMOTO.be)

STACK 28

AXO

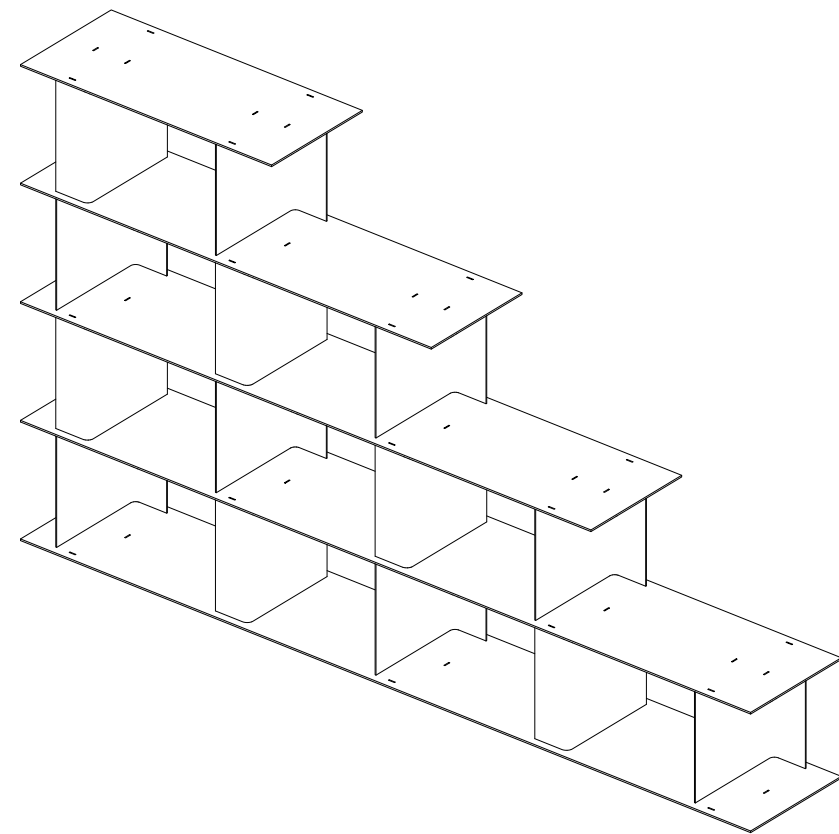

PLAN

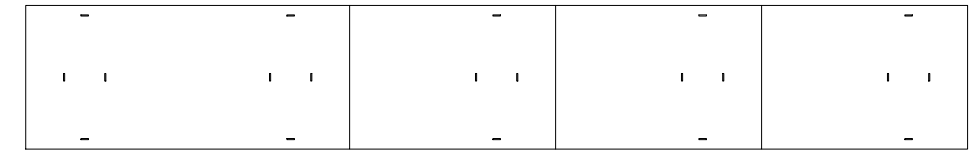

FRONT

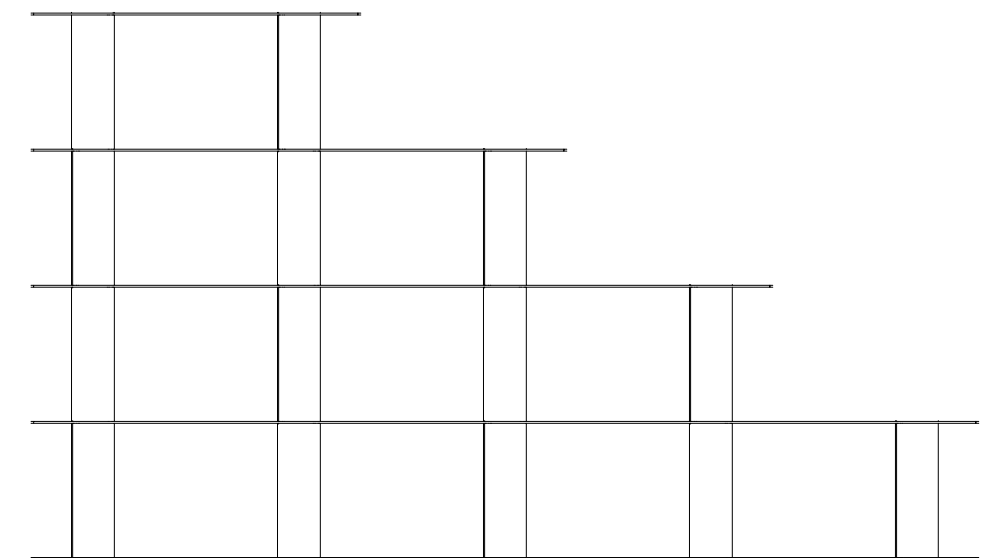

STACK by studio MOTO

[www.studioMOTO.be](http://www.studioMOTO.be) [info@studioMOTO.be](mailto:info@studioMOTO.be)

STACK 29

AXO

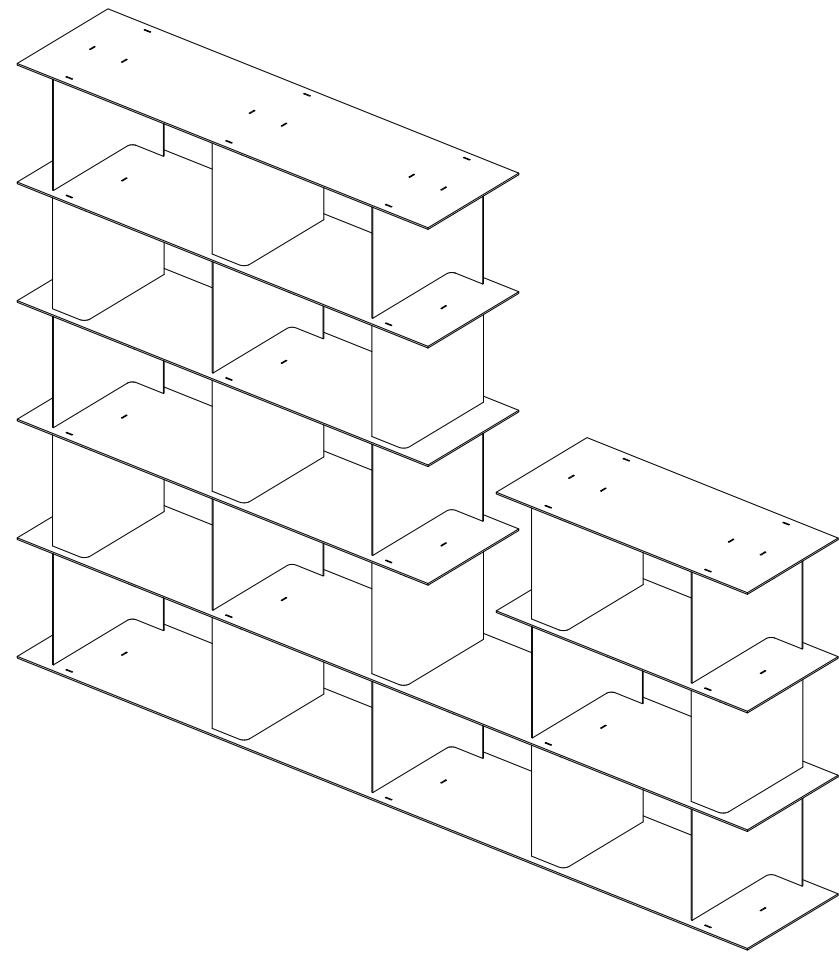

PLAN

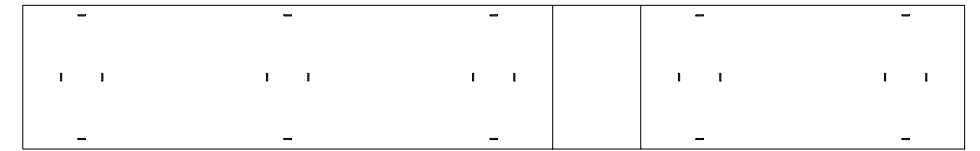

FRONT

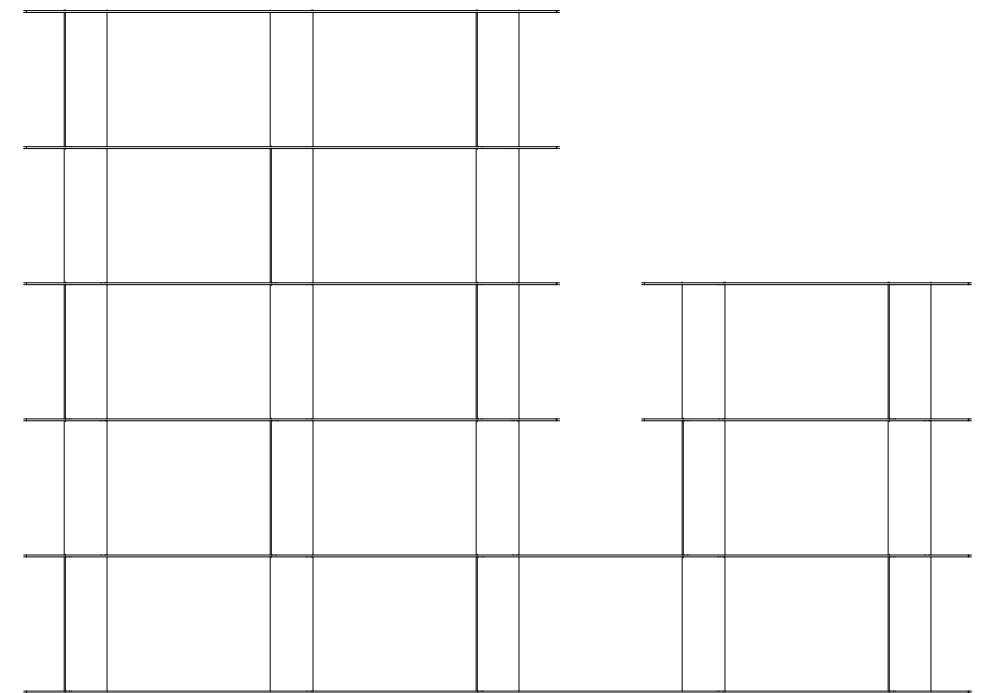

STACK by studio MOTO

[www.studioMOTO.be](http://www.studioMOTO.be) [info@studioMOTO.be](mailto:info@studioMOTO.be)

STACK 30

AXO

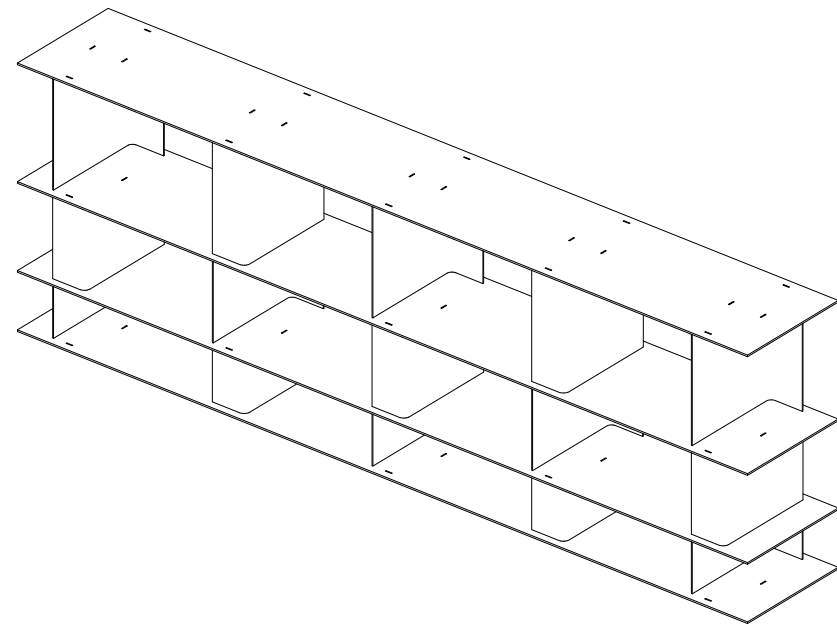

PLAN

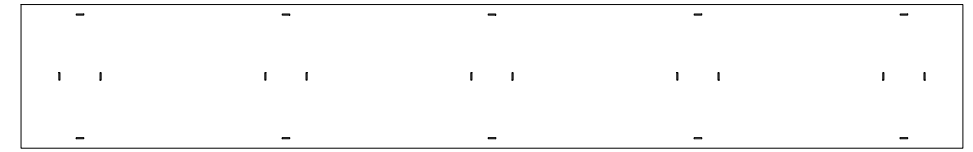

FRONT

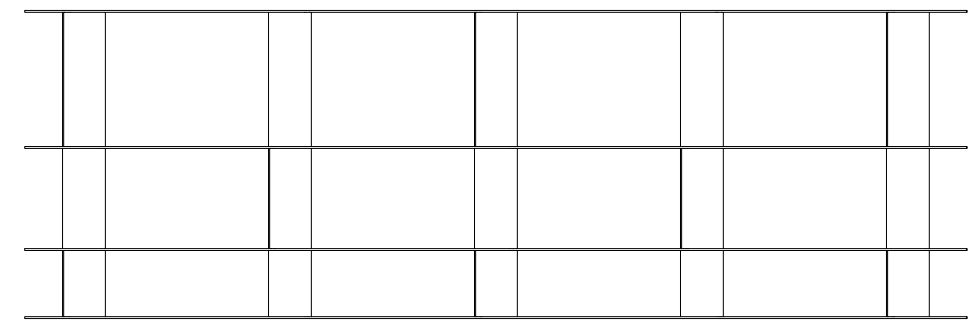

STACK by studio MOTO

[www.studioMOTO.be](http://www.studioMOTO.be) [info@studioMOTO.be](mailto:info@studioMOTO.be)

STACK 3 I

AXO

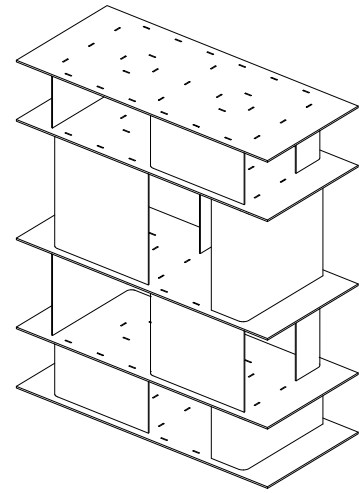

PLAN

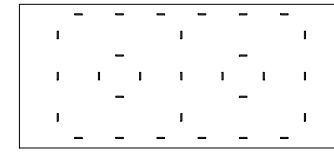

FRONT

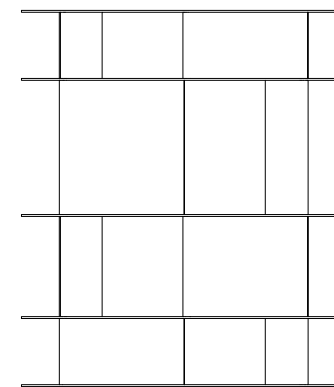

STACK by studio MOTO

[www.studioMOTO.be](http://www.studioMOTO.be) [info@studioMOTO.be](mailto:info@studioMOTO.be)

STACK 32



AXO

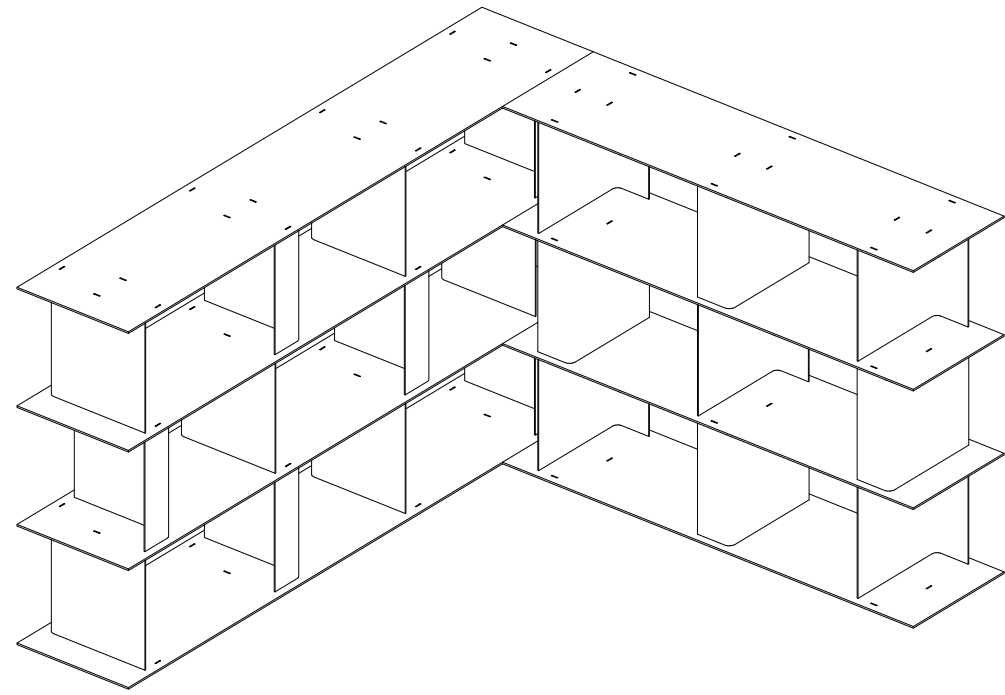

PLAN

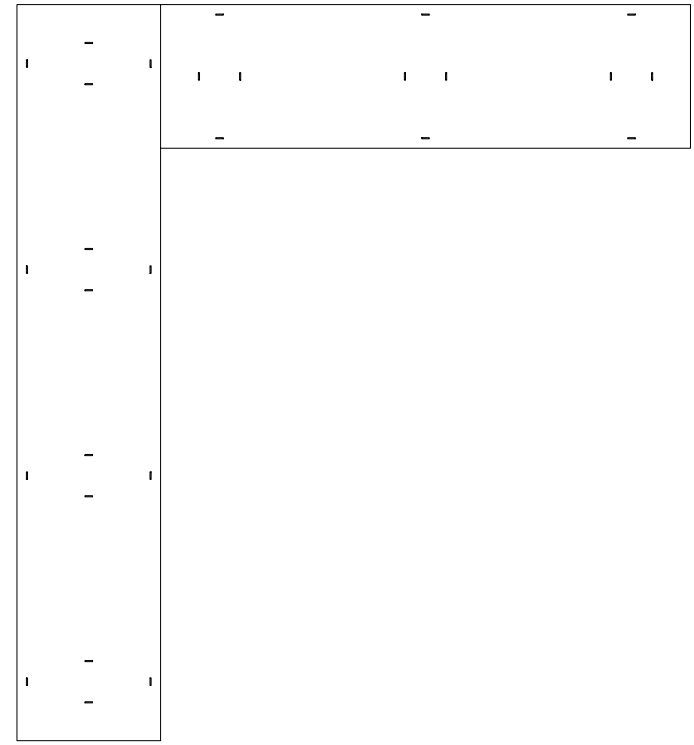

FRONT

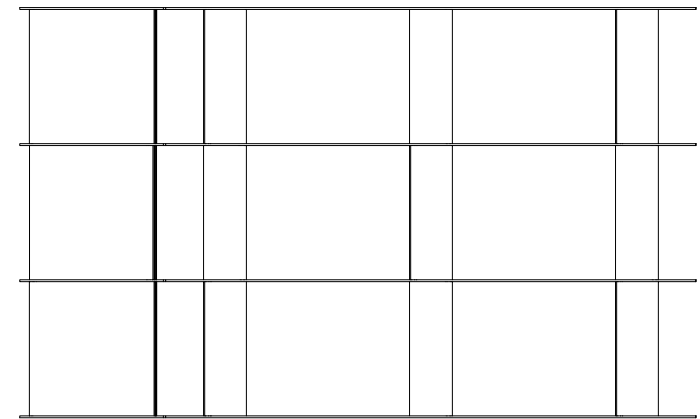

STACK by studio MOTO

[www.studioMOTO.be](http://www.studioMOTO.be) [info@studioMOTO.be](mailto:info@studioMOTO.be)

STACK 33

AXO

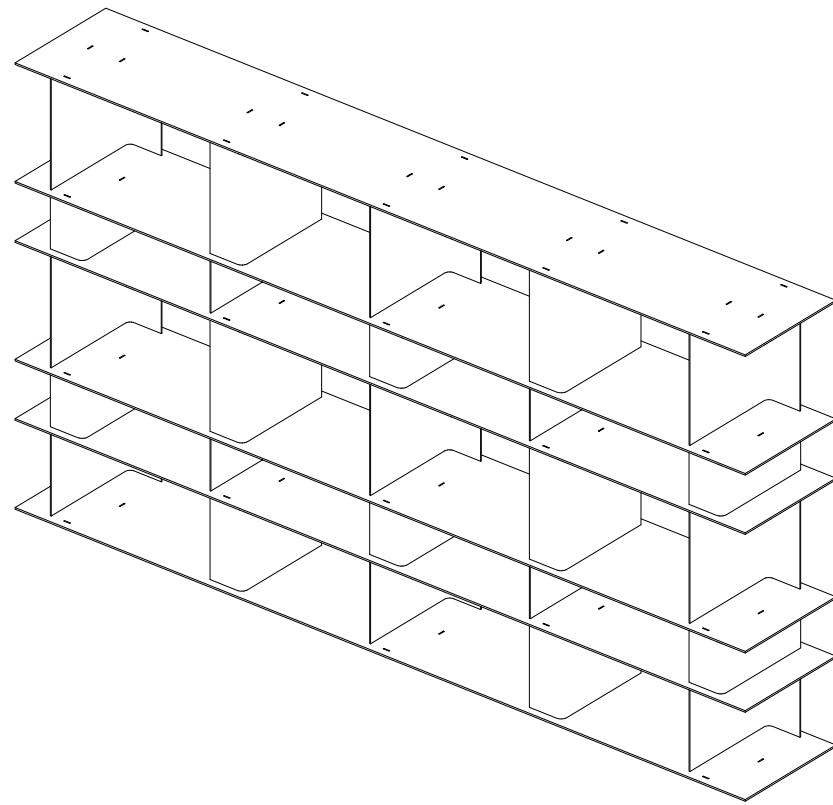

PLAN

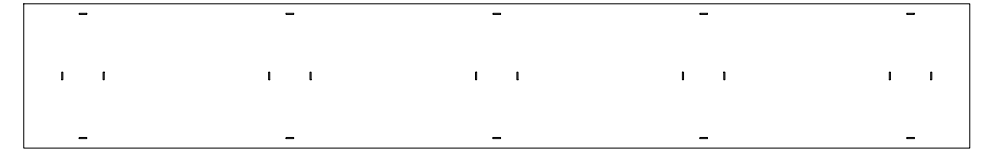

FRONT

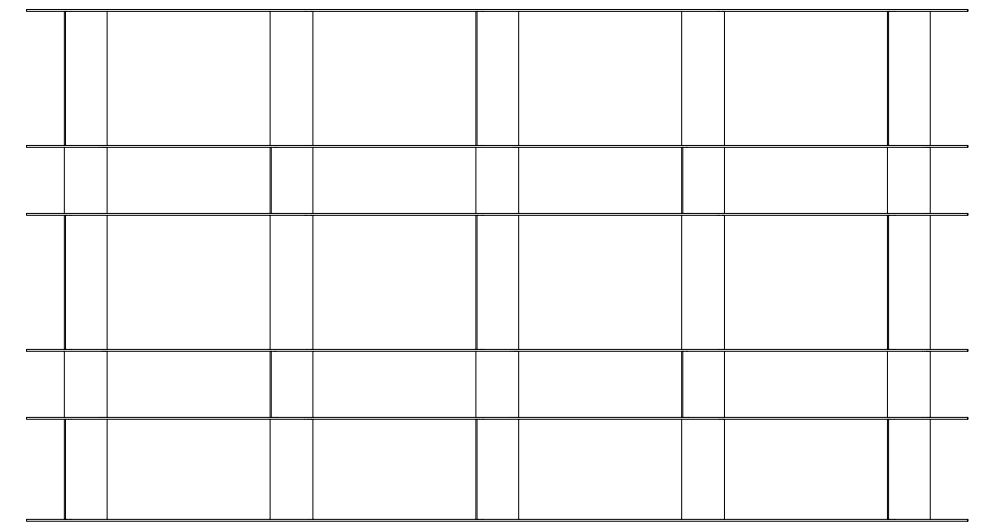

STACK by studio MOTO

[www.studioMOTO.be](http://www.studioMOTO.be) [info@studioMOTO.be](mailto:info@studioMOTO.be)

STACK 34

AXO

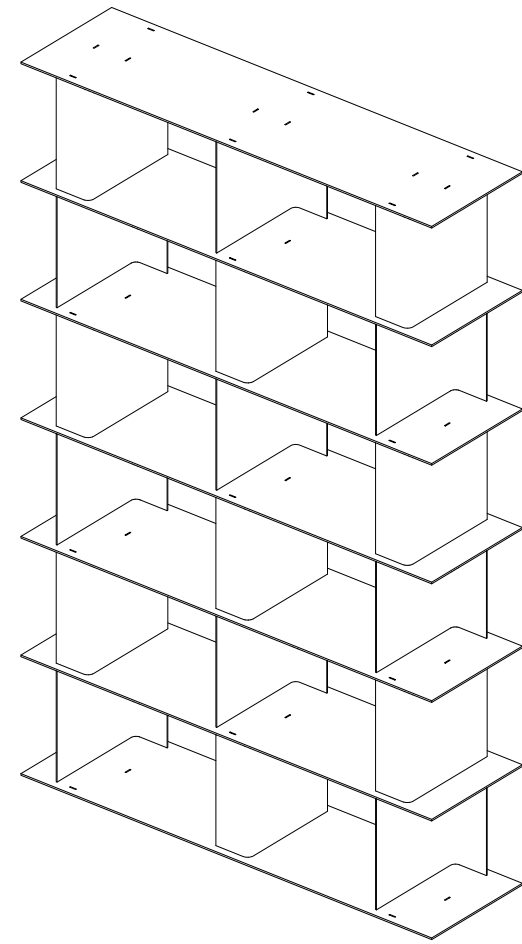

PLAN

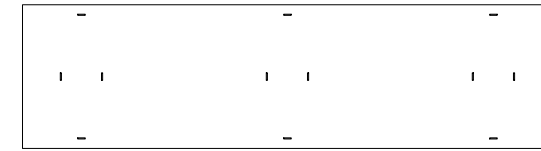

FRONT

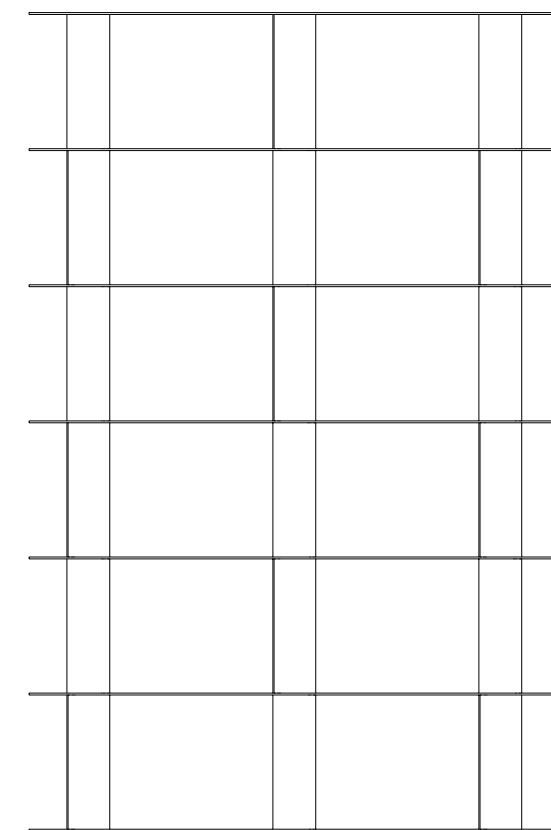

STACK by studio MOTO

[www.studioMOTO.be](http://www.studioMOTO.be) [info@studioMOTO.be](mailto:info@studioMOTO.be)

STACK 35

# STACK components (length\*width\*height)

amount

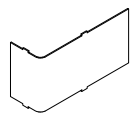

L-S  
(330x112x175mm)

x 0

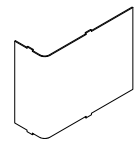

L-M  
(330x112x265mm)

x 0

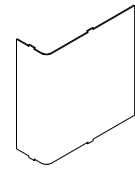

L-L  
(330x112x355mm)

x 0

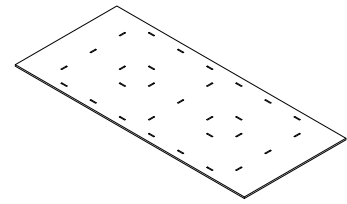

SHELF-S2  
(857x380x5mm)

x 0

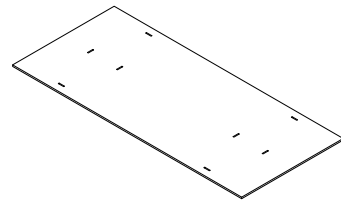

SHELF-S  
(857x380x5mm)

x 0

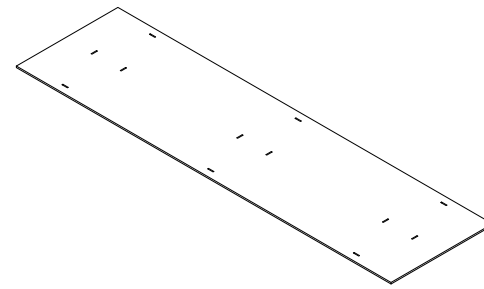

SHELF-M  
(1402x380x5mm)

x 0

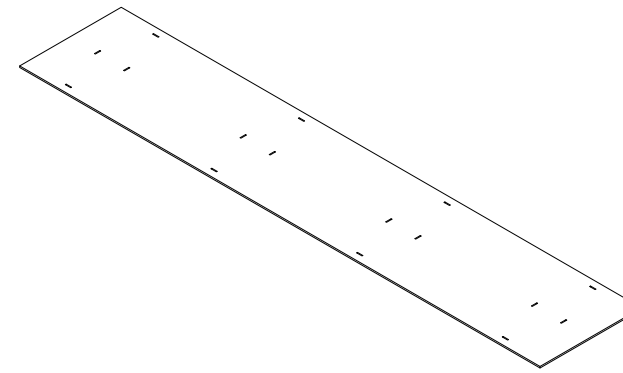

SHELF-L  
(1947x380x5mm)

x 0

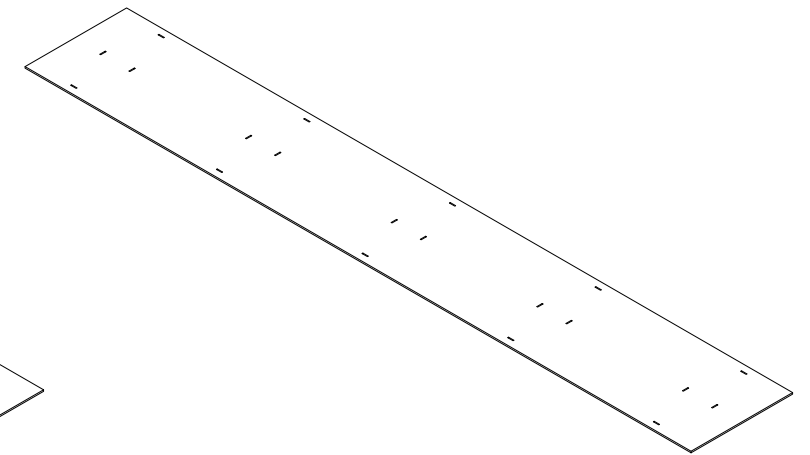

SHELF-XL  
(2492x380x5mm)

x 0

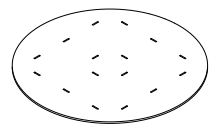

SQUARE-S  
(Ø517x5mm)

x 0

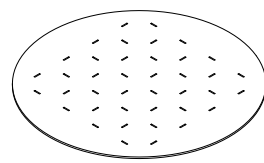

CIRCLE-M  
(Ø671x5mm)

x 0

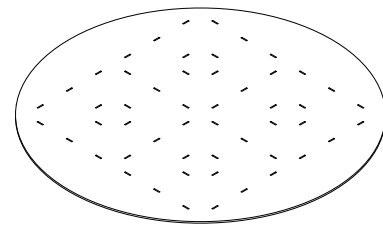

CIRCLE-L  
(Ø979x5mm)

x 0

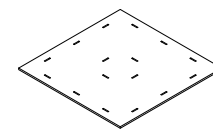

SQUARE-S  
(380x380x5mm)

x 0

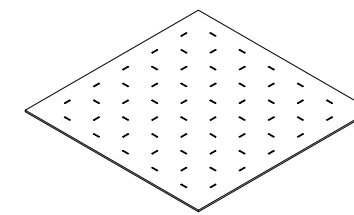

SQUARE-M  
(648x5mm)

x 0

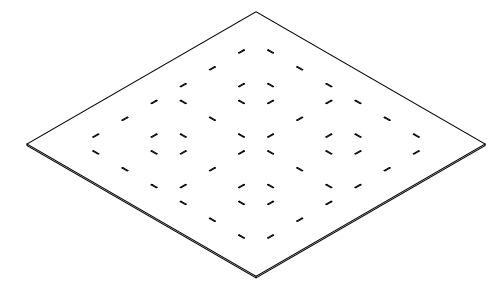

SQUARE-L  
(857x857x5mm)

x 0

studio MOTO © 2023 - All rights reserved and the drawing is issued on the condition that it is not copied, reproduced, refined or disclosed to any unauthorized person either wholly or in part, without the consent in writing of studio MOTO architects bv

## STACK by studio MOTO

[www.studioMOTO.be](http://www.studioMOTO.be) [info@studioMOTO.be](mailto:info@studioMOTO.be)

## COMPONENTS